

SPEED PULSE CONVERT UNIT No.1 / 2	
CODE	762-1301100
APPLICATION	MONKEY 125 (JB03) ※ This product might not work with non-genuine meter.
REMARK	GENUINE SPROCKET TEETH : 14T-37T

- Thank you for purchasing Kitaco product. Read and understand the instruction before installing.
- ※ The spare parts do not include the instruction sheet, please keep this safe.

ATTENTION (MUST READ)

- We are not responsible for violation of law or damages and accidents caused by assembling mistake and improper setting.
- Please ask authorized mechanic for assembling and setting.
- Do not modify the way which is not listed or it will cause damage and trouble. Do not give a strong shock and disassemble.
- Refer to the manufacturer service manual when installation.

SPEC	EFFECT Calculating speed by counter shaft (front sprocket shaft) rev(pulse signal), the actual speed might be different from display speed depending on counter shaft rev, sprocket numbers and tire sizes.
	EFFECT This product is setting parts to fix (manual setting) the speed display error caused by changing sprocket (reduction ratio) or tire sizes (perimeter). Genuine speed meter shows faster (bigger number) than actual speed. If you enter the revise value to close to actual speed, ABS error might ON.
NOTE!	▼INSTALLATION AND USING ● We are not responsible for the installation of special electrical customized vehicle. (HID, audio products, etc) ● This kit is not completely waterproof. Place it where it does not get wet or rain.
ATTENTION (MUST READ)	● For wiring process, please follow instruction and wiring illustration. ● This product is precision equipment. If installed to a lot of vibration place, it causes inability to perform as intended and at the worst case, it might break. If mounted beside of engine, it might malfunction by heat and vibration. ※ <u>Malfunction by heat and vibration is out of warranty. Be careful of it.</u> ● Do not install near the IG coil, high tension code, etc, it might cause of trouble. ● Do not disassemble. It might cause of trouble and break.

PACKING LIST			-
CODE	NAME		QTY
762-1301101	PULSE UNIT MONKEY 125 (JB03)		1
762-1301102	CONVERT HARNESS MONKEY125 (JB03)		1
700-9200100	TIE WRAP 100x2.5mm		2

INSTALL

- ※ For installing this product, removing/installing outer cowls is required. Refer to the genuine service manual when installation.
- ※ Please remove the battery to connect wire. It might cause of accident.

- 1 Connect speed sensor (3P coupler) and option connector (4P coupler) to insert speed convert harness.
- 2 Refer to the instruction No.2, do the revise setting of front/rear sprocket · tire size.

● WIRING ILLUSTRATION

Must to waterproof treatment to wiring and coupler point by roll vinyl tape, etc.

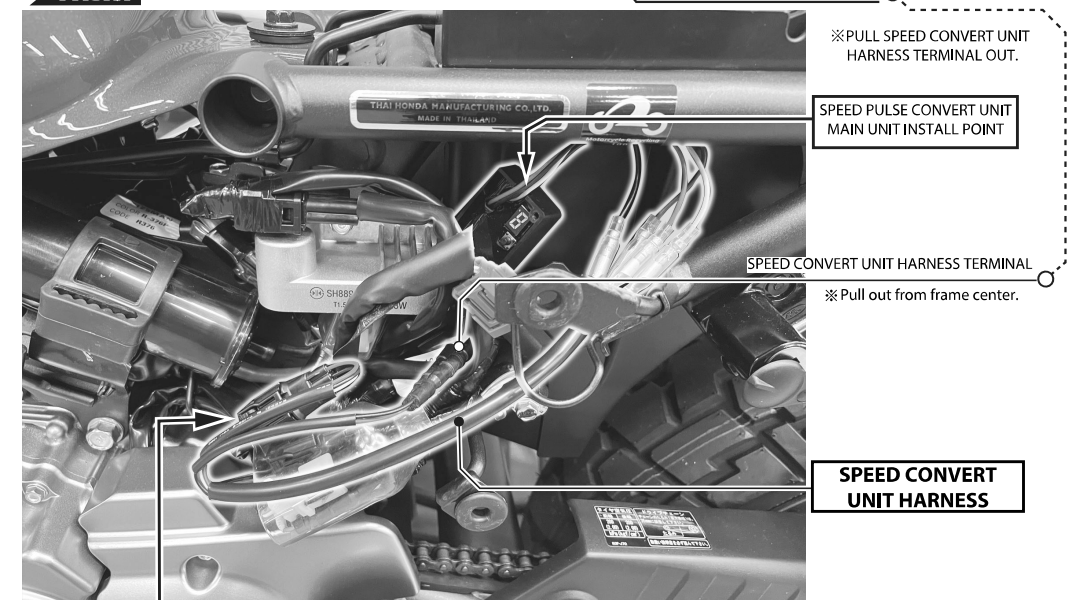
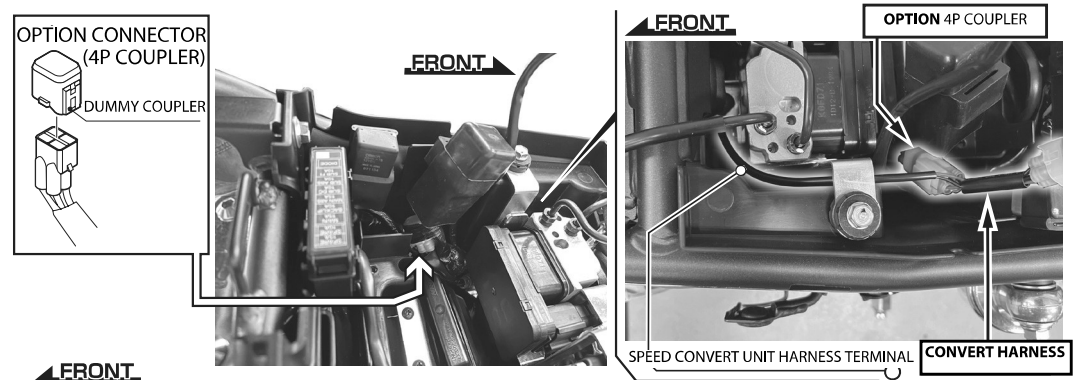
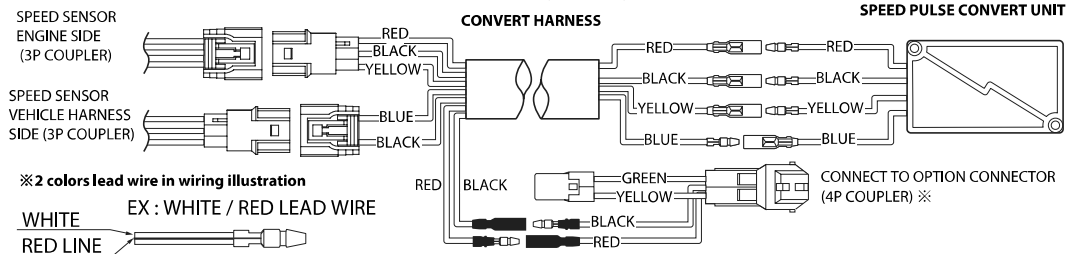

SPEED (VS) SENSOR 3P (BLACK) COUPLER (Remove L. side cover is required.)

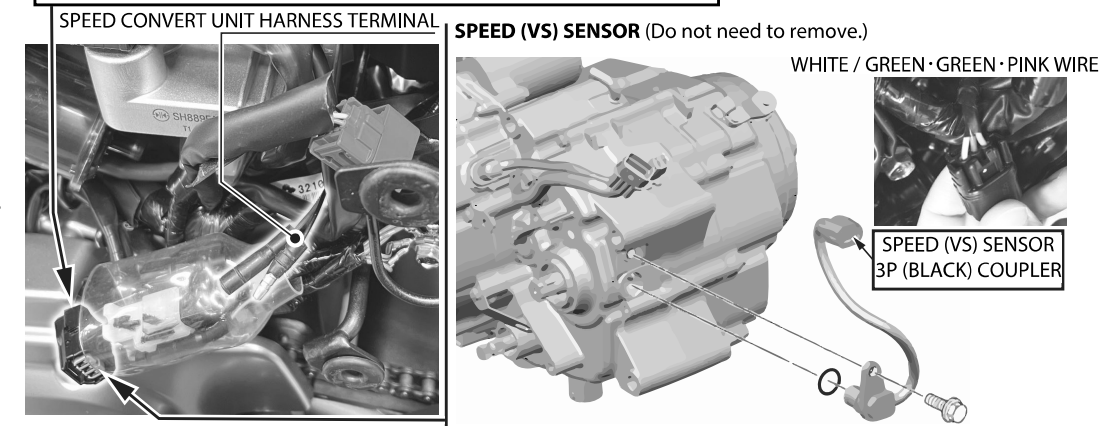

SPEED PULSE CONVERT UNIT No.2/2	
CODE	762-1301100
APPLICATION	MONKEY 125 (JB03) ※ This product might not work with non-genuine meter.
REMARK	GENUINE SPROCKET TEETH : 14T-37T

HOW TO SET UP AND USE

- Input the front / rear sprocket teeth and tire size to pulse output main unit. When setting, there is a counter and switch (push button) inside the main unit, please remove lid (with 2 screws).
 - Turn ignition on while pushing push button switch. After 7seg. LED is lit, leave the push button switch. It turns to setting mode, so please set up revise value of front / rear sprocket and tire sizes referring to the diagram. [Refer to the setting diagram.]
 - Finish setting mode. Display the [F] → [R] → [r] in this order, then turn the ignition off after turning back to [F].
- ※ [Default setting is {genuine sprocket teeth : 14T-36T} {revise value:100%} .]
- ※ Getting back to [F] to save the setting.
Make sure not to loosen any parts before riding. Please do a test ride to check the meter display correctly.
- ※ Do not set up on public road. Riding with wrong setting may cause of road traffic law violation.

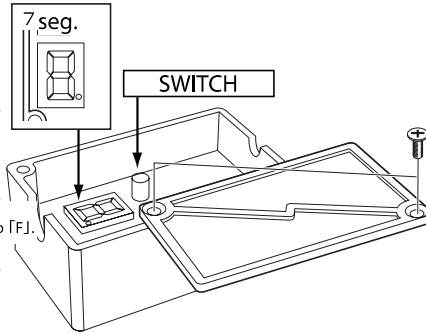

● HOW TO CALCULATE TIRE SIZE REVISE VALUE

Measure the tire O.D. and note it.
Calculate the O.D. length changing to % following below, then input the numerical value to tire size revise value setting mode.
If you do not revise, input the default [100].

	TIRE SIZE	O.D.	REVISE VALUE	REMARK
-	MONKEY 125 GENUINE TIRE	130/80-12 69J	513mm	100% Default setting
Ex	TT93GP	120/80-12	502mm	約 98% ← INPUT VALUE
-		140/85-12	543mm	約 105%

● FRONT / REAR SPROCKET • TIRE SIZE FIXING SETTING DIAGRAM

HOW TO START

STEP1

Turn ignition key to ON while pushing button switch.

PUSH BUTTON

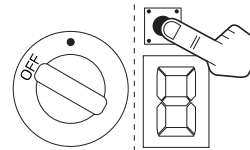

STEP2

Turn the key to ON while pushing button.

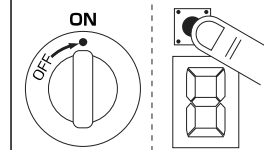

STEP3

After 7seg. LED (shows F) is lit, leave the button.

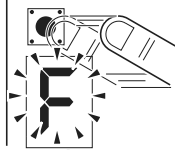

ATTENTION!
(If display shows other than "F", turn ignition key OFF, then continue the process from beginning to show "F" again.)

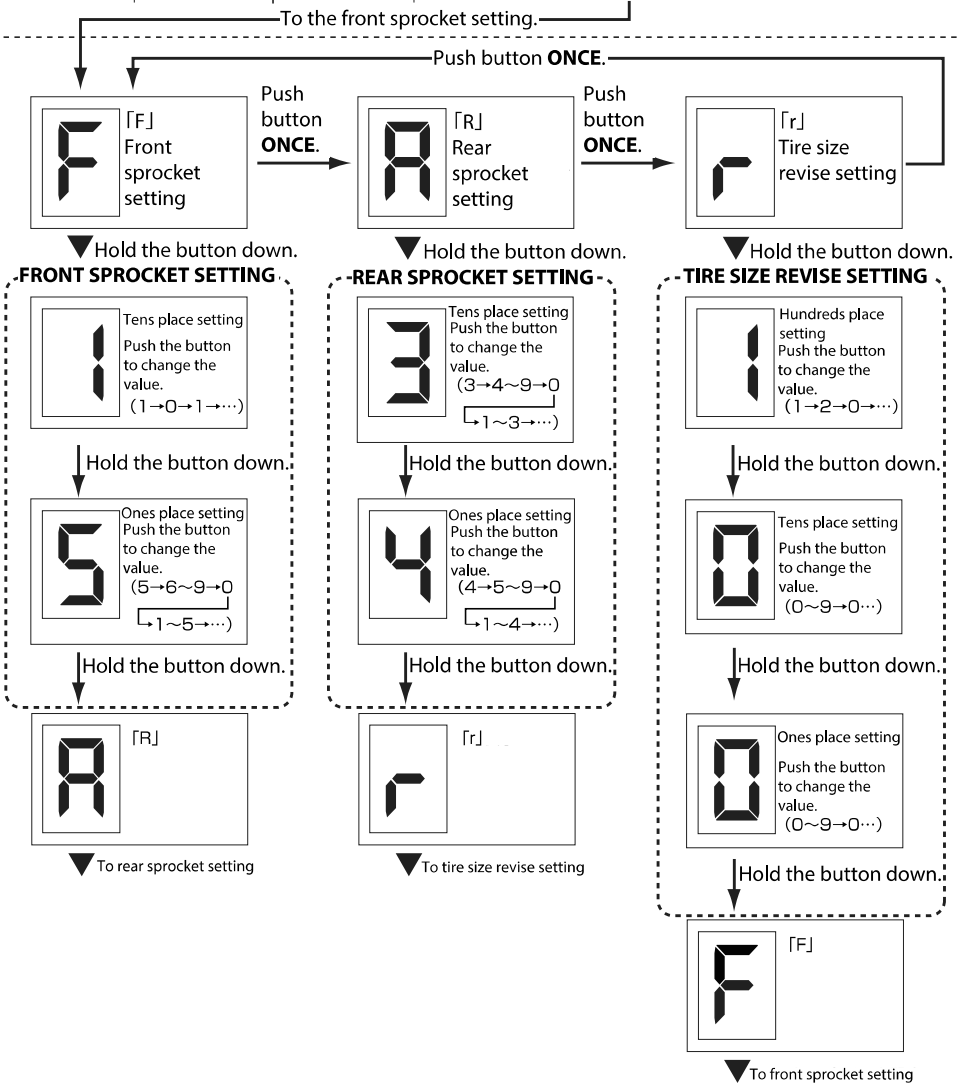

220127 M-T