

### CLASSIC DOWN MUFFLER for SUPER CUB 50 / 110

|             |  |  |
|-------------|--|--|
| CODE        | 50cc (STAINLESS STEEL) 543-1153500               | 110cc (STAINLESS STEEL) 543-1439500                    |
| APPLICATION | SUPER CUB50 / PRO (AA09 / 07) / CROSS CUB (AA06) | SUPER CUB 110 / PRO (JA44 / 42) / CROSS CUB 110 (JA45) |

Thank you for purchasing Kitaco product. Read and understand the instruction before installing.

#### ATTENTION (MUST READ)

- This product increases exhausting system and bring out special performance. However, setting up is required. If you don't, it might cause of decrease performance, burning and trouble. Please understand before installing.
- We are not responsible for violation of law or damages and accidents caused by assembling mistake and improper setting.
- This instruction sheet is for the instruction for stock condition. Do not modify the way which is not listed or it will cause damage and trouble.
- This product is designed and made exclusive for application models, do not use other models.
- Out put characteristic is different from stock, please ride safely.
- Please ask authorized mechanic for assembling and setting. Ask a specialist at specialty shop if you do not understand the role of the surrounding parts.
- Refer to the manufacturer service manual when installation.
- Bolts and nuts may get loosen by engine vibration. Make sure not to loosen any bolts and nuts before driving.



This sheet is intended for the person who has basic knowledge for maintenance. Do not operate if you do not have skill and knowledge.



Do not touch the engine parts (cylinder, crankcase, muffler, engine oil, etc) right after engine operation. Make sure to start the installation after the engine parts are completely cool.



**FLAMMABLES**  
Inflammable high gasoline is used during operation.



Do not modify the way which is not listed or it will cause damage and trouble.



The shape is different from genuine one, please be careful of burning until get used to it.

\*( ) is 1 set QTY.

| ATTACHED PARTS                 |  |                     |       |
|--------------------------------|--|---------------------|-------|
| FIGURE                         | NAME                                   | CODE                | QTY   |
| -                              | CLASSIC DOWN MUFFLER (STAINLESS STEEL) | -                   | × 1   |
|                                | FLANGE CAP BOLT                        | M8X30 080-0560030   | × 2   |
|                                | FLANGE LOCK NUT                        | 8mm 001-0550008     | × 2   |
| OPTION PARTS (SOLD SEPARATELY) |  |                     |       |
|                                | MUFFLER GASKET                         | (XH-06) 963-1000006 | (× 2) |



210323 Y-N  
3-8-13 NAGATA,  
HIGASHI-OSAKA,  
OSAKA, JAPAN  
<https://www.kitaco.co.jp/>

(This is just a installation illustration, please refer to the manufacturer service manual.)

- \* Basically, reuse genuine parts if it is unattached. If there is a hard degradation like a blem, fatigue and wear etc on the reuse parts, please change to new ones.
- Install Kitaco muffler temporarily with attached parts as illustration. (Refer to the illustration.)
- \* Recommend to change muffler gasket to new one (sold separately).
- \* When installing muffler, removing step ease to install.
- Install removed srock parts, tighten with specified torque while adjusting each parts. Make sute not to leak exhaust.

#### INSTALLATION ILLUSTRATION

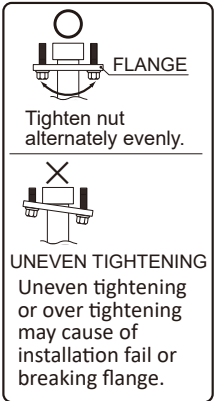
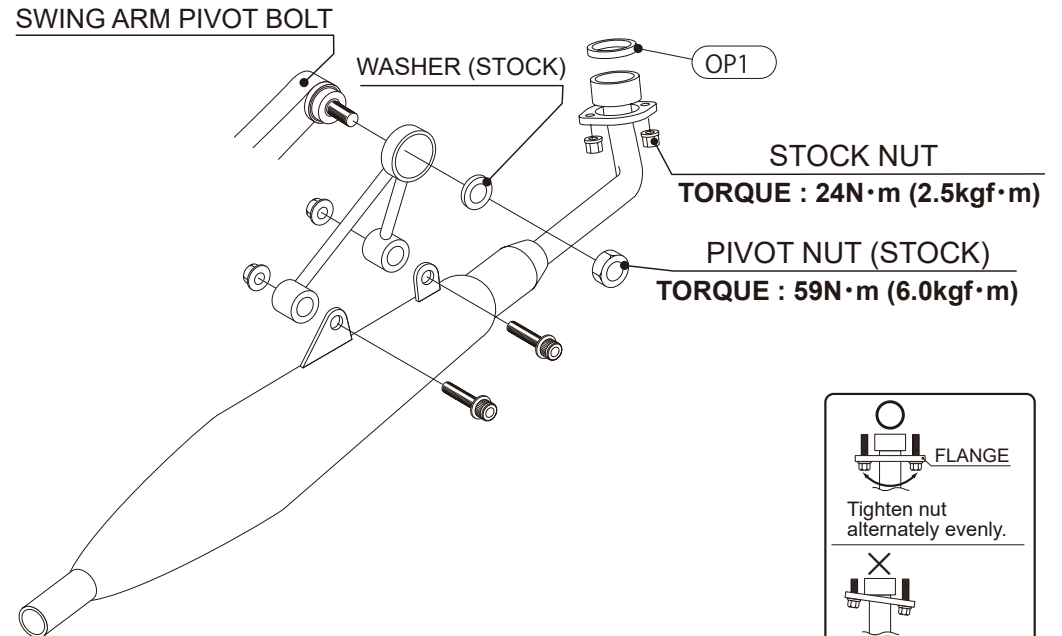

#### ATTENTION!

After riding a lot, surface of the product (especially exhaust pipe) might change its color, but it's not unusual. If want to remove burning, please use specified chemicals that sold commercially.

- If starting engine with oil or dirt, it changes color or burned (only that place). Please wipe it with degreaser before starting engine.
- Do not leave this product with water. It might cause of tarnish or rust.

#### HOW TO TAKE CARE

- Rust and corrosion caused by surface oxidation is caused by exhaust high heat. Genuine muffler is the same. This is characteristic, which cannot avoid. However, it only occurs to surface. Applying heat resist silicone wax to delay tarnish.