

KITACO SHOCK ABSORBER

CODE	[N350S]520-1086190 (OSS-ZH-52085500)	
APPLICATION	CD50 / BENLY 50S / BENLY CL50	SUPER CUB70 FNO,C70-8300003 ~
	SUPER CUB50 FNO,C50-8500034 ~ 0095210 FNO,C50-0200001 ~ FNO,AA01-1000001 ~ 1699999	SUPER CUB70(12V MODEL) FNO,C70-1000001 ~ 1699999
	SUPER CUB50(FI MODEL) FNO,AA01-1700001 ~	SUPER CUB90 FNO,HA02-1300016 ~
	SUPER CUB50(FI MODEL) FNO,AA04-1000001 ~	SUPER CUB110 FNO,JA10-1000001 ~
	*SUPER CUB50 PRO is not compatible.	*SUPER CUB110/PRO (JA07/10 model) are not compatible.
REMARK	○FREE LENGTH : 350mm ○CAM TYPE 5 STEPPED PRELOAD ADJUST ○1SET OF 2	

●Thank you for purchasing Kitaco product. Read and understand the instruction before installing.

ATTENTION (MUST READ)

- Please ask authorized mechanic for assembling and setting. Ask a specialist at specialty shop if you do not understand the role of the surrounding parts.
 - We are not responsible for violation of law or damages and accidents caused by assembling mistake and improper setting.
 - After installation, steering stability has changed compared to the stock rear shock. Please ride safely.
 - Refer to the manufacturer service manual when installation.
 - Bolts and nuts may get loosen by engine vibration. Make sure not to loosen any bolts and nuts before driving.
 - Do not modify the way which is not listed or it will cause damage and trouble.
- ※Metal/resin products get discolored/rust for ages as well as how to use. Please understand when using.

HOW TO INSTALL

※If there is a hard degradation like a blem, fatigue and wear etc on the reuse parts, please change to new ones.

- 1) Stable the vehicle body by using maintenance stand.
- 2) Remove covers if necessary.
- 3) Remove stock rear shock and install Kitaco one.
- 4) Adjust each parts and make sure not to loosen any parts before riding.

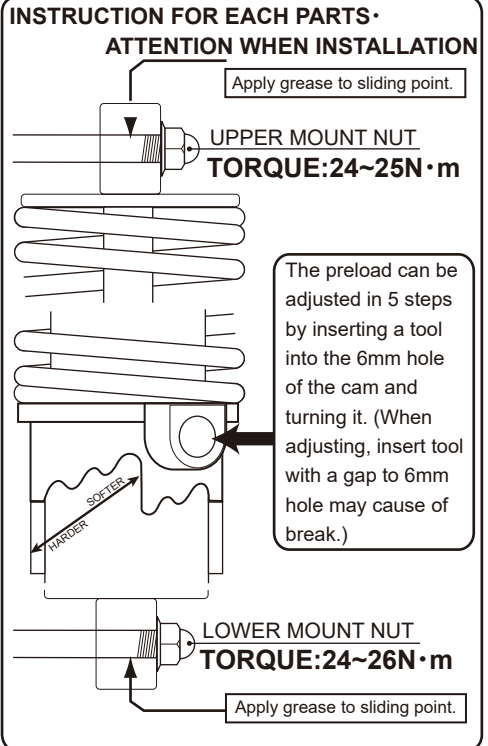

140627



株式会社 千石

3-8-13 NAGATA,
HIGASHI-OSAKA,
OSAKA, JAPAN