

SUPER OIL COOLER KIT [3/5ROW] UP type No.1/2		
CODE	(3 ROW) 360-1301100	(5 ROW) 360-1301200
APPLICATION	MONKEY 125 (JB03)	
REMARK	You need to remove genuine air cleaner. Please use another UNI FILTER KIT(515-1452100). We recommend to use oil catch tank for deal with blowby gas's crankcase breather hose.	

● Thank you for purchasing KITACO product. Read and understand the instruction before installing.

ATTENTIONS(MUST READ)

- SUPER OIL COOLER KIT is for racing use only. Use this product with your responsibility.
- This product is to cool engine oil to avoid heating troubles to cause performance decrement.
- We are not responsible for damages and accidents caused by assembling mistake and improper setting.
- Do not modify the way which is not listed or it will cause damage and trouble.
- Please ask authorized mechanic for assembling and setting. Ask a specialist at specialty shop if you do not understand the role of the surrounding parts.
- Refer to the manufacturer HONDA service manual when installation.
- Bolts and nuts may get loosen by engine vibration.
- SUPER OIL COOLER KIT is designed and made exclusive for MONKEY 125(JB03), do not use on other models.
- Metal/resin/alumite products get discolored/rust for ages as well as how to use. Please understand when installing.

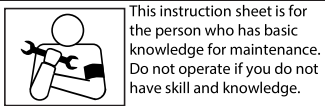

This instruction sheet is for the person who has basic knowledge for maintenance. Do not operate if you do not have skill and knowledge.

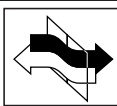

Toxic, highly-volatile gasoline is used during operation. Be sure to ventilate the room. Do not operate for hours in a hermetically closed room.



FLAMMABLES
Inflammable high oil is used during operation. The use of products causing fire or smoke is strictly prohibited.



Don't touch the parts(cylinder, crankcase, muffler etc) right after engine operation. Make sure to start the installation after the engine part are completely cool.



Do not check the sparking of spark plug outside of the cylinder. There are dangerousness of explosion.

PACKING LIST(Refer to the figures & illustration right side)				3MC	5MC
FIGURE	NAME	CODE	QTY		
1	OIL COOLER STAY	360-1301191	x1	x1	
2	(MAP) SENSOR STAY	(Intake pressure) stay	515-1452104	x1	x1
3	TAPPET HOLE COVER	SILVER	360-1452001SL	x1	x1
4	GASKET	TAPPET HOLE COVER	310-1452001	x1	x1
5	OIL COOLER	(3 ROW CONDENSER)	360-0500100	x1	-
		(5 ROW CONDENSER)	360-0500200	-	x1
6	FLANGE HEXAGON BOLT	M6x12	062-0561012	x3	x3
7	FLAT WASHER	6.5x16x1.6mm	090-0907006	x4	x4
8	GROMMET	7.5x9x14x7T	752-9999099	x2	x2
9	GROMMET COLLAR	6.2x7.5xL7	093-0900003	x2	x2
10	CAP BOLT	M6x25	060-0500025	x4	x4
11	OIL HOSE	600mm	991-0000060	x1	x1
12	ALUMINIUM SEALING WASHER	10mm	771-0500999	x8	x8
13	UNION NIPPLE (BLACK)	M10/6mm HOSE	990-0900901	x4	x4
14	ALMINIUM BANJO BOLT (RED)	M10xP1.25	771-0900900	x4	x4
15	HOSE BAND	Φ 8 ~ 12	995-0500012	x4	x4
16	CAP BOLT	M5x10	050-0500010	x2	x2
17	FLAT WASHER	5x12x1.0mm	090-0900005	x2	x2
18	IAT EXTEND HARNESS	For intake air temperature sensor	360-1300192	x1	x1
-	MS TIE (BLACK)	100x2.5	700-9200100	x3	x3

OPTIONAL PARTS

OIL CATCH TANK KIT (CARBON/ALUMINIUM) JB03/JC92	
ALUMITE COLOR	CODE
(RED)	616-1452220
(BLACK)	616-1452250
(SILVER)	616-1452260



Rendering image

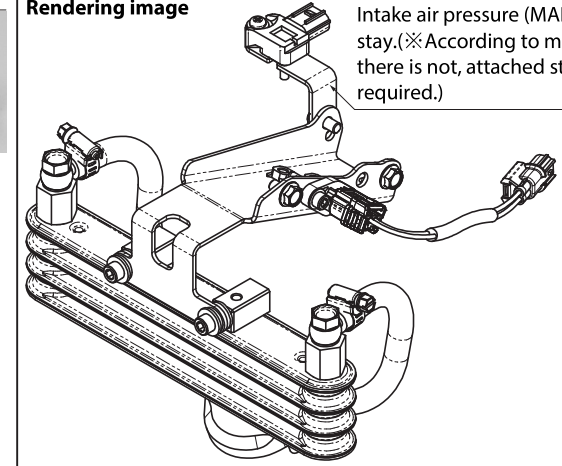

Intake air pressure (MAP) sensor/stay. (※According to models. If there is not, attached stay is not required.)

※ Basically, reuse genuine parts if it is not attached. If there is a hard degradation like scratch, settling, friction, etc... on the reuse parts, please change to new one.
 ※ Please check attached document NO.2 that how to install.

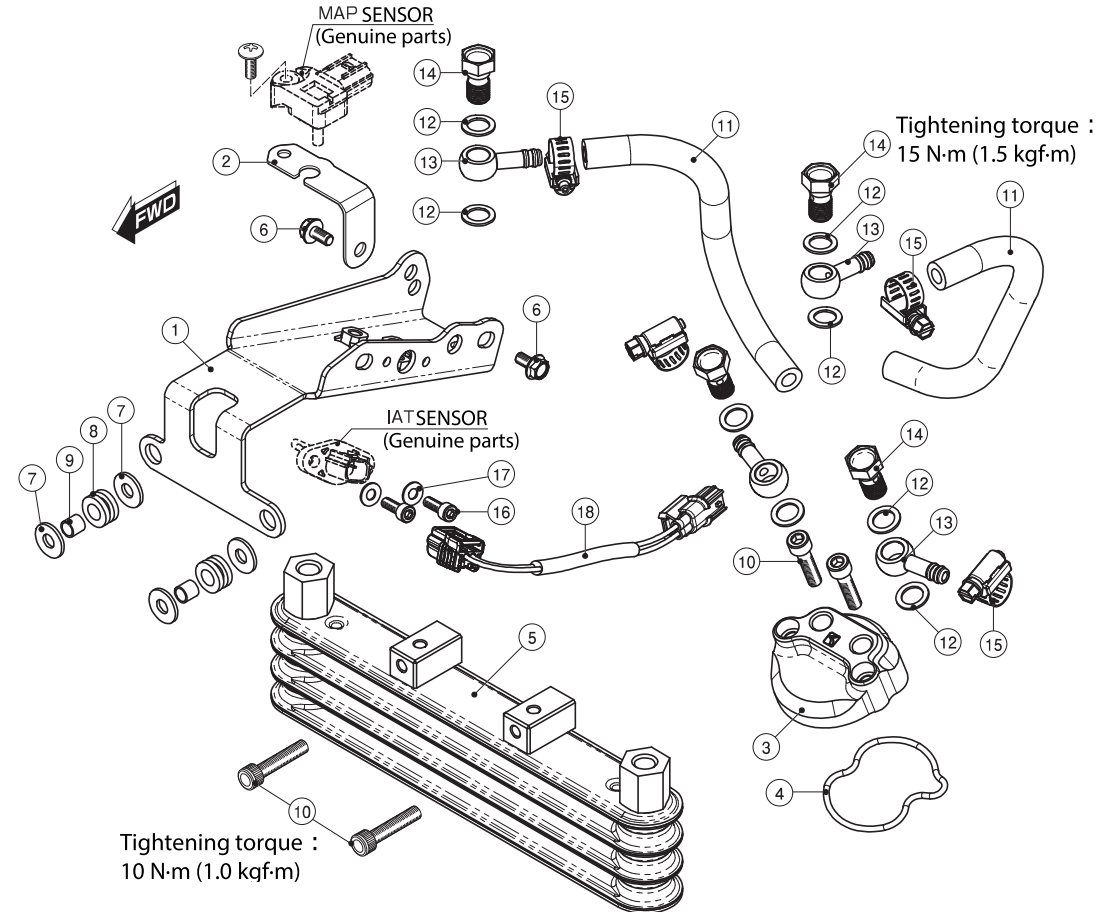

SUPER OIL COOLER KIT [3/5ROW] UP type No.2/2

CODE	(3ROW) 360-1301100	(5ROW) 360-1301200
APPLICATION	MONKEY125 (JB03)	
REMARK	You need to remove genuine air cleaner. Please use another UNI FILTER KIT(515-1452100). We recommend to use oil catch tank for deal with blowby gas's crankcase breather hose.	

REMOVING OF EXTERIORS

1-1 Remove the garnish with sliding forward from air cleaner case. (right side of illustration)

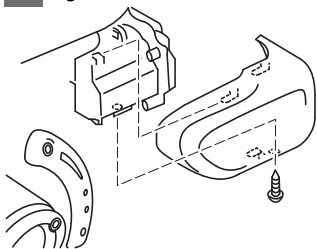

1-3 Tie the fuel drain hose which is from air cleaner case to sensor harness.

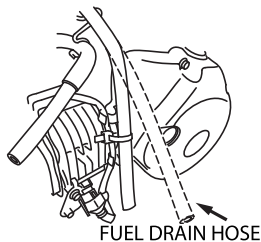

INSTALLING OIL COOLER STAY

2-1 Install the stay for condenser with attached bolts to the air cleaner case mounting position.

Tightening torque : 10 N-m (1.0 kgf-m)

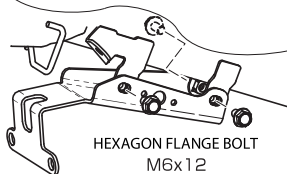

For JB03, tighten the MAP sensor stay together.

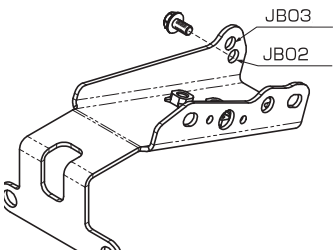

1-2 Remove the intake air temperature(IAT)/intake air pressure(MAP), sensor,fuel drain hose and crank case breather hose from air cleaner case.

※ Reuse the intake air temperature (IAT) / intake pressure (MAP) sensor and part of clip nut. (※MAP may not exist depending on the vehicle type)

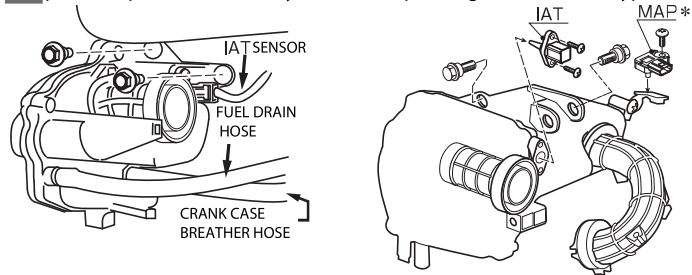

INSTALLING INTAKE AIR TEMPERATURE(IAT) STAY

2-2 Install the IAT sensor to stay for condenser, then connect the extend harness.

Tightening torque : 3.4 N-m (0.3 kgf-m)

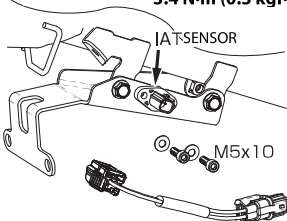

INSTALLING INTAKE AIR PRESSURE(MAP) SENSOR STAY

2-3 Install the MAP sensor to the stay with genuine bolts. (According to the model)

2-4 On the right side, tighten the sensor stay to air cleaner case mounting position together with M6x12 bolt.

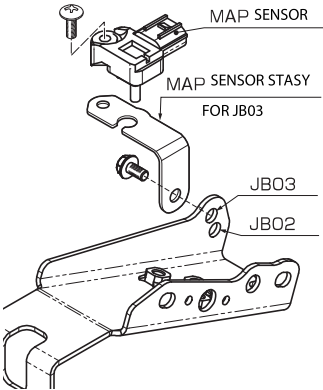

INSTALLING OIL COOLER

3-1 Exchange intake side genuine valve adjust cap to kitaco one.

Tightening torque : 10 N-m (1.0 kgf-m)

Install attached union nipple / bolt, aluminum washer temporarily.

※ If there is a hard degradation like scratch, settling, friction, etc... on the reuse parts, please change to new one.

※ Tighten bolts & nuts with specified torque.

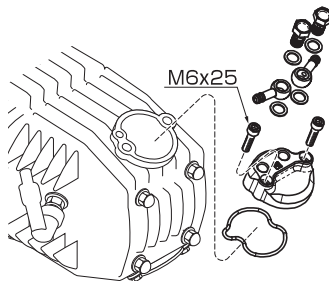

3-2 Refer to illustration, install the condenser, and route oil cooler hose.

Tightening torque

: 10 N-m (1.0 kgf-m)

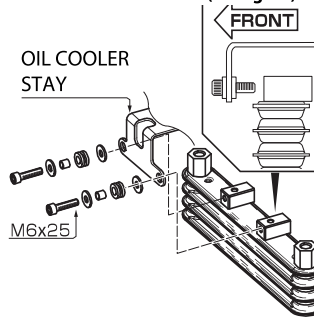

3-3 Decide the mounting position, cut the oil hose moderately and connect to the place for taking out oil. Make sure that the oil hose is not touched by muffler or engine.

Banjo bolt tightening torque : 15 N-m (1.5 kgf-m)

▲ Add engine oil (standard amount + 75~100cc) for oil cooler capacity.

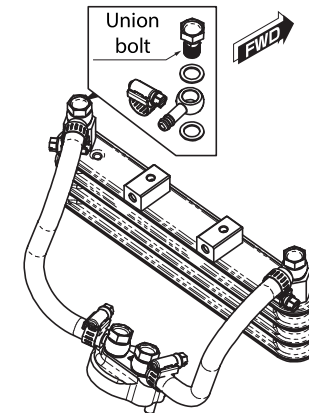

ATTENTION!

※Do not start engine quickly. Keep idling before oil goes all inside the cylinder head lubrication.