

OIL CHANGE FULL SET (K-PIT)	CODE : 70-390-02010
APPLICATION : ADDRESS V125S (CF4MA) / ADDRESS V125/-G (CF4EA/CF46A) GSX-S125 (DL32B) / GSX-R125 (DL33B) / GIXXER (NG4BG)	

- Thank you for purchasing Kitaco product.
Read and understand the instruction before installing.

ATTENTION!

- This product contains filtration device(filter), rubber seal(O ring, washer),etc that need when changing motorcycle engine oil.
- This product is made exclusive for the models. Do not use other models. Please check application vehicles.
- Please change oil element after 100~2000km ride for the first time. After that, change it every 5000~6000km ride.

ATTENTION!

- Please ask authorized mechanic for assembling and setting.
- Specific tool is needed if the element is cartridge type. Please check the size first.
- When changing element, prepare specified amount of engine oil, operate with oil change.
- When changing element, operate when engine oil is completely cool.
- Place the vehicle on flat ground, make sure not to fall while installation.
- Refer to the manufacturer service manual when installation. This instruction sheet only shows how to change oil, it might different from actual installation. Please understand before installation. We are not responsible for violation of law or damages and accidents caused by assembling mistake and improper setting.

HOW TO INSTALL

- 1) Remove oil level gauge/ oil filler cap to ease drain oil.
- 2) Remove oil drain bolt, then drain engine oil.
- 3) Remove oil element (filter).
 - Use specified tool if it is cartridge type oil element.
 - If it is only element type, it is set inside the engine (crank case), remove oil element cover installation bolt, remove oil element and rubber seal inside.
- 4) Apply a little engine oil or grease to new oil element rubber seal (O ring).
- 5) Check the shape of new element, then install.
 - ※ Follow specified torque of each vehicle.
- 6) Apply engine oil to attached O ring and washer, then install the specified position (groove).
- ※ According to washer shape, it might have specified direction. Be careful of it.
- 7) Tighten drain bolt with specified torque of each vehicle by using attached drain washer.
- 8) Pour specified amount of engine oil.
- 9) Start engine with low rpm (idle), make sure not to leak oil.

ATTENTION!
Install O ring to specified position (groove) correctly.
If O ring tightened to outside of the groove, it might cause of oil leak.

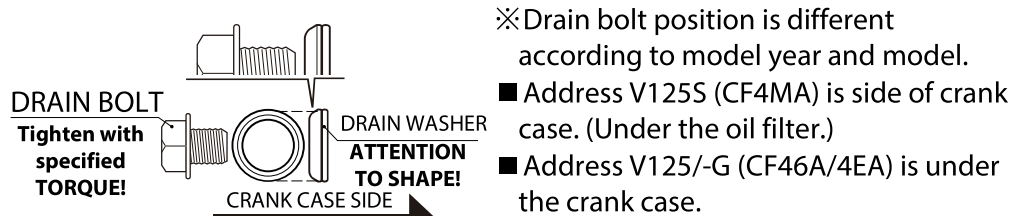
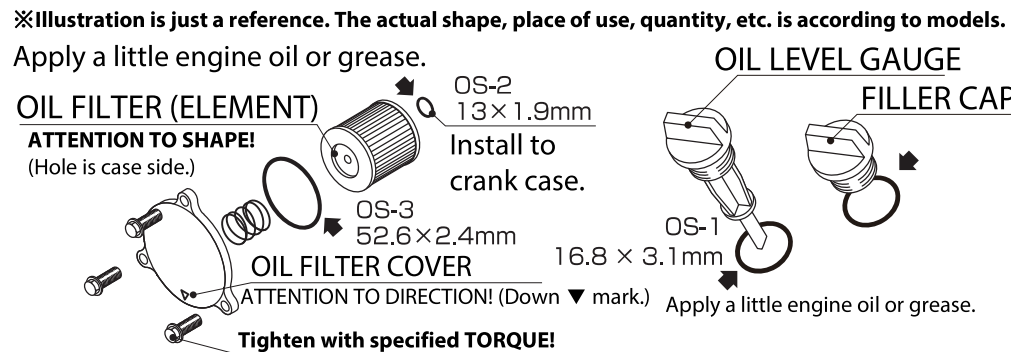

PACKING LIST			
NAME	CODE	QTY	TORQUE
OIL ELEMENT : S-06	70-390-12060	1	
DRAIN WASHER : 10x14x3.6	092-0505001	1	DRAIN BOLT : 18N · m
OIL LEVEL GAUGE O RING : OS-1	70-967-32010	1	
FILTER O RING : OS-2	70-967-32020	1	
FILTER COVER O RING : OS-3	70-967-32030	1	COVER BOLT : 10N · m